

Product
display

System solution



One of the basic tasks of the energy storage system is to overcome the time or locality difference between the supply and demand of the power grid and ensure the safety of the power grid. The energy storage in the power grid can effectively regulate the power and energy, which is an important premise for realizing the intelligent management of the power grid and an effective means of rational utilization of renewable energy, and provides a good way to solve the problem of energy shortage.

The second task of the energy storage system is to realize the independent operation of new energy photovoltaic power generation, distributed wind power generation and small-scale micro-grid system, and to form a grid system with battery system that can operate independently into a relatively independent grid system. Its significance lies in that it can be used as the basic unit of smart grid to realize the establishment of independent micro-grid in remote areas. To save a lot of investment in auxiliary distribution.

Home photovoltaic energy storage integrated solution

As photovoltaic subsidies gradually decline and the market gradually shifts to encouraging energy storage, regions with high electricity prices in more developed regions will gradually realize the marketization of photovoltaic + energy storage.

Family AC coupling system solutions

As more and more households are equipped with photovoltaic systems, energy storage needs to be installed in the original system, and energy storage converter equipment can be installed directly on the AC side without changing the installation condition of the original equipment, so as to realize the demand of household energy storage.

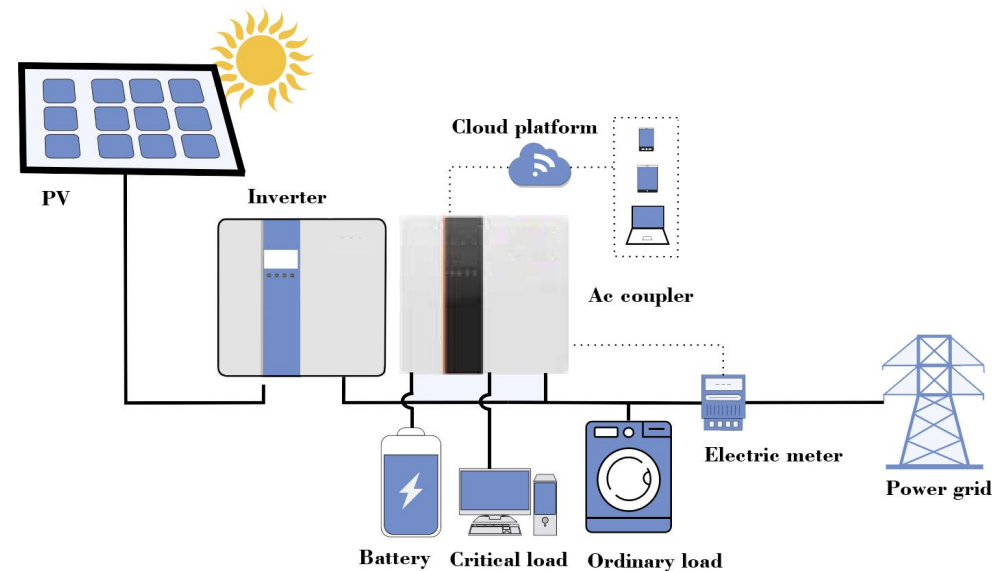
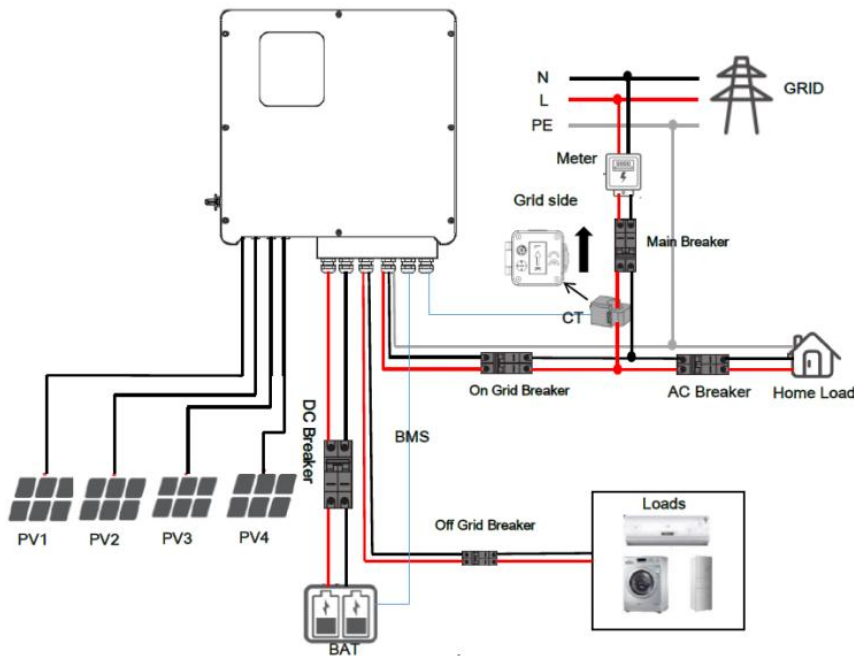

System Solution - Industrial and commercial energy storage

Energy storage system can be used to realize peak-valley arbitrage if the peak-valley electricity price is large in industry and commerce. In addition, energy storage for industry and commerce can also reduce transformer capacity charges, reduce the maximum transformer electricity demand, delay the construction of power distribution capacity for users and save costs for enterprises and industry as backup power supply.

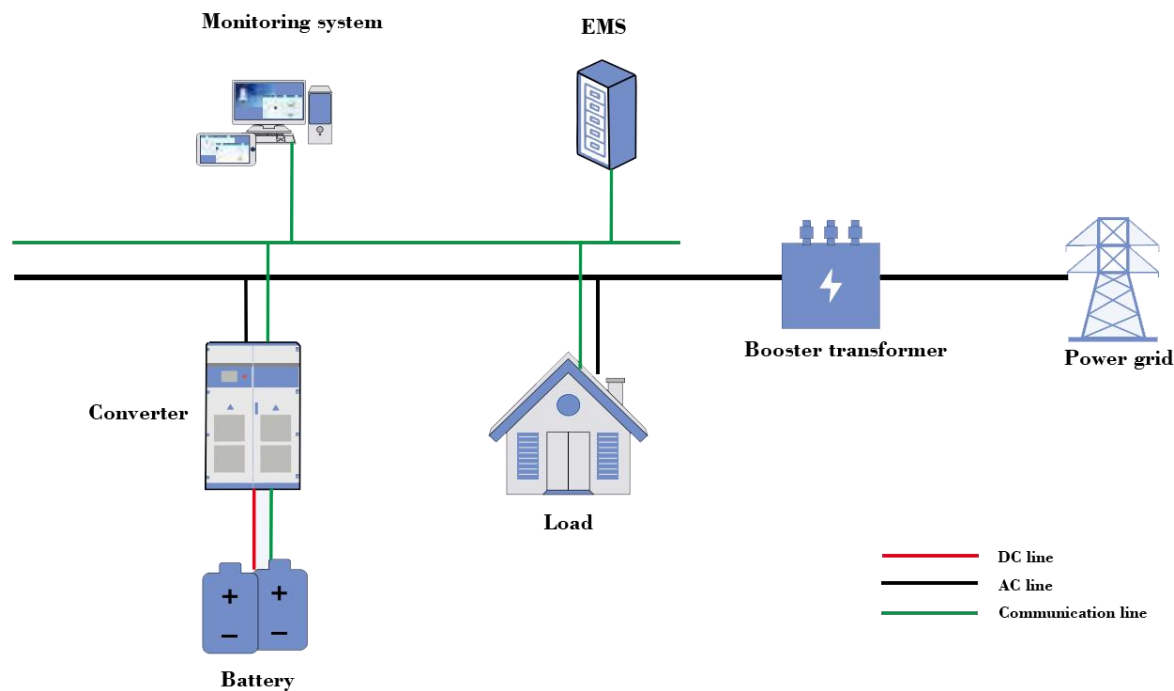

- Cut peaks and fill valleys
- Transformer maximum demand management
- Transformer capacity limited capacity expansion replacement
- Reactive power compensation and APF improve power quality
- PCS comes with isolation transformer, strong load adaptability, high reliability, more suitable for industrial and commercial applications.
- Can participate in the auxiliary services of demand side response and power dispatching, frequency modulation and peak regulation.
- BP series integrated energy efficiency management.

System Solution - Photovoltaic power station energy storage

The energy storage system can transform the existing photovoltaic power station with high on-grid electricity price, solve the phenomenon of photovoltaic power station light abandonment, eliminate photovoltaic random fluctuations, improve the power output quality of photovoltaic power plant, make photovoltaic power station gradually become adjustable power, can generate 96-point power prediction report, and gradually let photovoltaic power station participate in auxiliary services such as peak regulation and frequency regulation.

AC busbar scheme

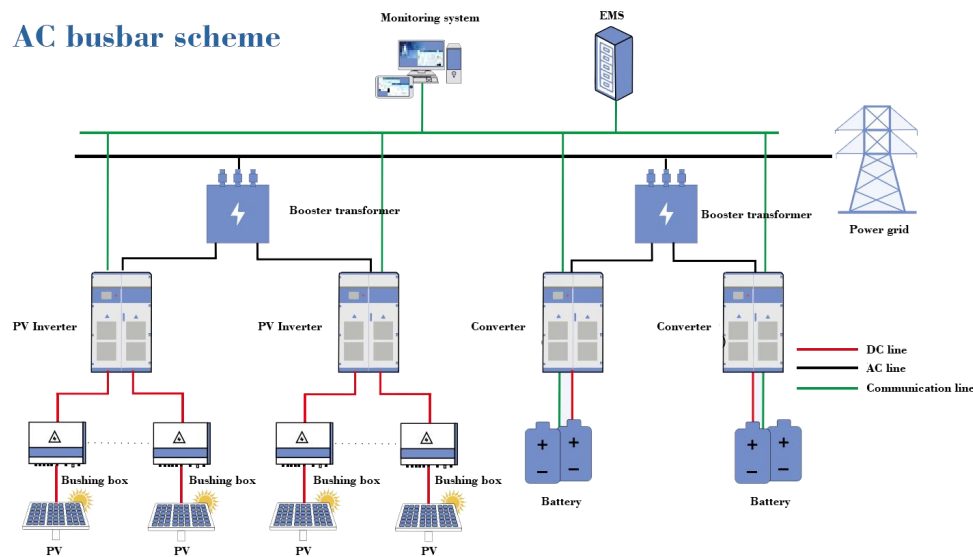

DC busbar scheme

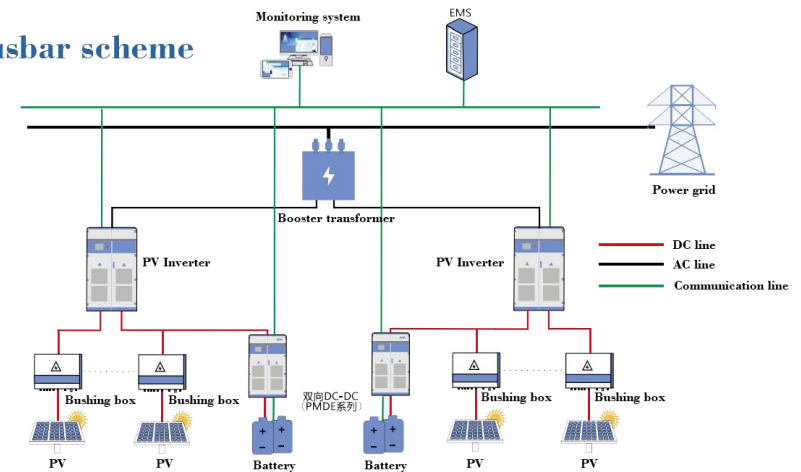

- Reduce waste light and improve economy
- Smooth random power fluctuations and improve power quality
- Improve power and forecast accuracy
- Photovoltaic power station energy storage to participate in auxiliary services

Microgrid system is a power generation and distribution system that can realize self-control, protection and management according to predetermined goals. It can be connected to the external power grid to form a networked microgrid, or it can be isolated to form an independent microgrid. Energy storage system is an indispensable unit in microgrid, which can achieve internal power balance, provide stable power for load, and improve power reliability. Achieve seamless switching between connected and off-grid.

Grid-connected microgrid solution

Energy storage plays the role of stabilizer and regulator in the integrated energy utilization of wind, light, biomass, gas and storage. A large number of distributed power sources are connected to the distribution network, leading to unstable supply and increasing peak-valley difference in consumer power consumption. Therefore, distributed micro-grid energy storage is implemented in the distribution network to regulate the coordinated operation of distributed power sources and loads. It can make up for the negative impact of distributed output randomness on the safety and economic operation of the power grid, and participate in the auxiliary services such as peak regulation, frequency regulation and voltage regulation of the power grid.

- Multi-energy input, basically realize self-use and reduce dependence on large power grid.
- Efficient and flexible, suitable for a variety of renewable energy power generation systems.
- Ac busbar connection, convenient centralized management.
- Energy storage system can realize micro grid black start.

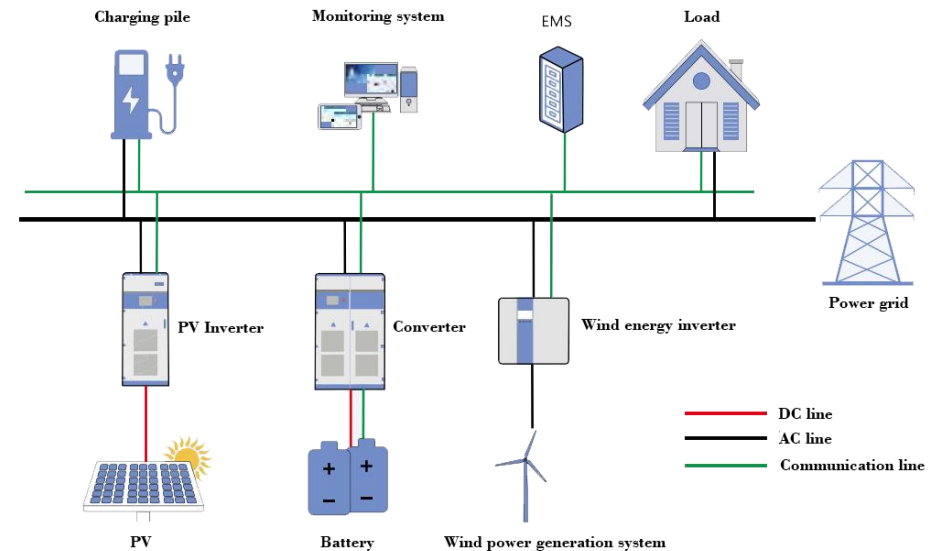

Microgrid system is a power generation and distribution system that can realize self-control, protection and management according to predetermined goals. It can be connected to the external power grid to form a networked microgrid, or it can be isolated to form an independent microgrid. Energy storage system is an indispensable unit in microgrid, which can achieve internal power balance, provide stable power for load, and improve power reliability. Achieve seamless switching between connected and off-grid.

Off-grid microgrid solution

In remote areas, it is difficult to be covered by traditional power grids, but the local light resources or wind resources are rich, which is very suitable for the establishment of light (wind) wood storage independent micro-grid to solve the local power consumption problem.

- High power (MW class above) independent micro grid, AC busbar scheme, reduce the coupling of each input source, improve reliability.
- The system operates under off-grid regulation, and the energy storage system or diesel generator provides voltage and frequency support for the entire microgrid.
- The energy management system (EMS) analyzes and predicts the power usage of photovoltaic, wind power, and load to realize the safe, reliable and economical operation of the microgrid system.

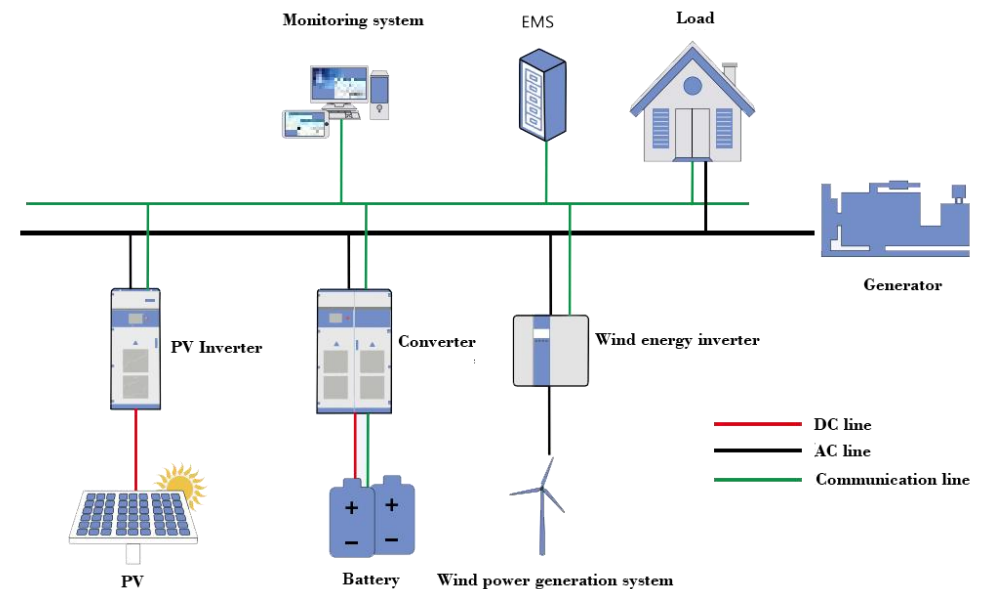

The construction of "optical storage and charging" integrated charging station is an innovative attempt in the construction of new energy vehicle charging station. The charging station uses clean energy for power supply and stores electric energy after photovoltaic power generation. Photovoltaic, energy storage and charging facilities form a micro-grid, which intelligently interacts with the public power grid according to demand, and can realize two different operation modes: grid-connected and off-grid. On the basis of charging stations, photovoltaic power generation, energy storage system, emergency charging and other systems are added for intelligent interaction of the power grid, which plays a key role in assisting the power grid peak regulation, smoothing the output of electric energy and improving the stability of the power grid.

AC busbar solution

AC busbar solution of integrated optical storage and charge power station is a common optical storage and charge solution at present. It is widely used in the expansion of charging station system and the application of multi-energy complementary system.

- It can realize the integrated container solution of photovoltaic, energy storage and battery. Large access power range, flexible design.
- It can be used for power supply in areas without power, integrated application of optical storage and charge, power sale in industrial parks, large charging stations and other micro grid applications.
- Energy storage system reduces peak and valley, reduces power distribution capacity, and solves the problem of power distribution expansion.

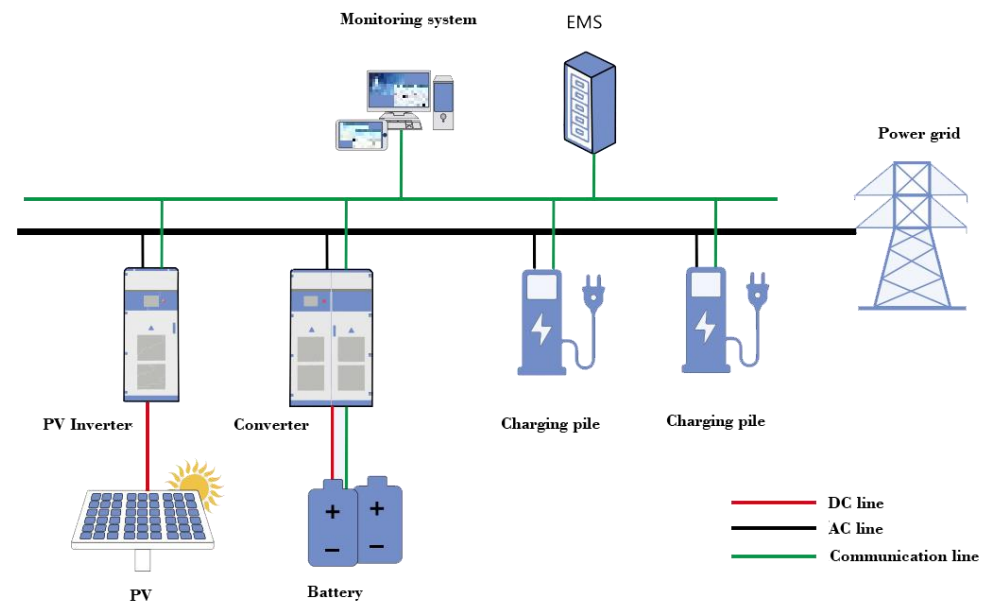

Some remote areas without power need to build their own power grid due to sparse population and far distance from the main grid. Photovoltaic energy storage and micro-grid technologies can be adopted to realize system power supply. Different circuit topologies can be adopted according to different power requirements to meet different customer needs.

Medium power off-grid system

Weak current area, electricity is extremely unstable, underdeveloped countries in the world, there are still a large number of areas without electricity. To solve the problem of reliable and stable power supply in weak and no-power areas is the demand of people's livelihood. With the decreasing cost of photovoltaic and energy-storage KWH, the independent micro-grid of optical and firewood storage is a good solution to solve this problem of people's livelihood.

- Highly integrated and easy to use.
- Widely used in backward power facilities or islands and other areas without electricity.
- Integrated energy management system (EMS), under the premise of safe and stable load power supply, more use of new energy development, less use of mains or diesel engine, improve the economic effect of power generation.

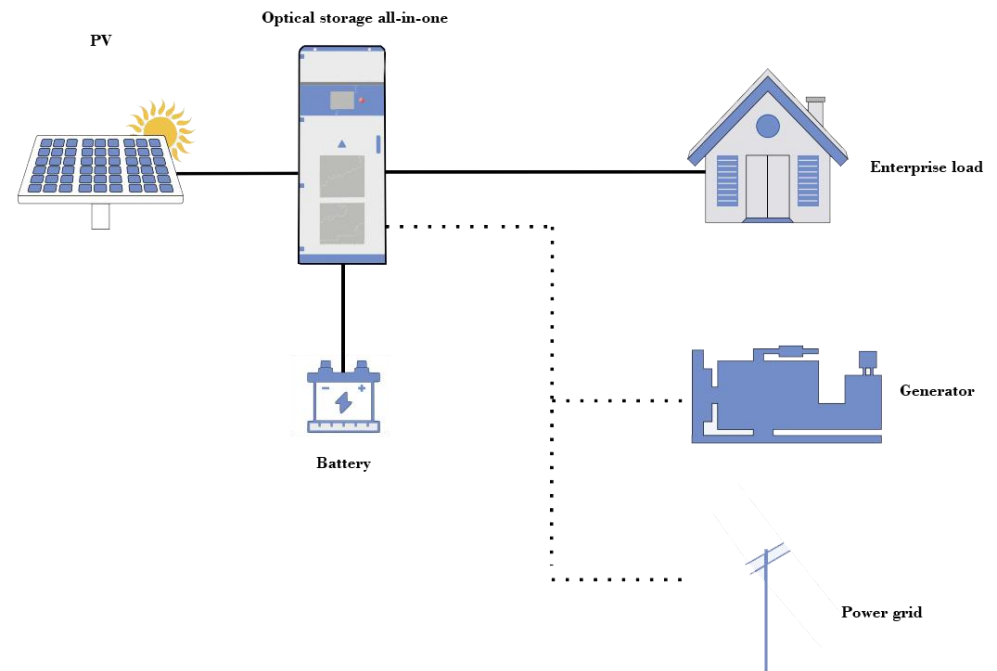

Some remote areas without power need to build their own power grid due to sparse population and far distance from the main grid. Photovoltaic energy storage and micro-grid technologies can be adopted to realize system power supply. Different circuit topologies can be adopted according to different power requirements to meet different customer needs.

Low-power off-grid system

Photovoltaic off-grid system can be used to solve the problem that some remote uninhabited areas have no electricity for a long time.

- It can solve the problem of long-term absence of electricity in remote mountainous areas
- It can be used as a convenient energy source for basic household electricity
- Field equipment power supply

